

Finite Element Analysis and simulation of missile impact on Nuclear Reactor Containment Structure

Kalesh Khan A^a & Rama M^b

^aPost graduate Student, Government College of Technology Coimbatore, Tamil Nadu, India

^bAssistant professor, Government College of Technology Coimbatore, Tamil Nadu, India

ABSTRACT: Nuclear Powerplants are planned and designed to withstand high internal, external pressures and impact loads. International Atomic Energy Agency recommends Design Extension Condition (Impact of Missile or Aircraft) that is a mandatory condition to be fulfilled by Containment structure. In this Finite Element Analytical study, wall joint section of containment structure is modelled and analysed for Missile body impact, and it is observed that, the surface induced pressure in wall section is dynamic in nature, as it varies with respect to time and load. By obtained 3D simulation and contour pattern on PCC panel, it is found that the induced stress is bending pressure.

1 INTRODUCTION

Nuclear reactor power plants are special structures, in which Containment Structure is identified as most critical and strong structure. On June 27, 1954, the world's first nuclear power station to generate electricity for a power grid, the Obninsk Nuclear Power Plant, commenced operations in Obninsk, in the Soviet Union. The world's first full scale power station, Calder Hall in the United Kingdom, opened on October 17, 1956. So, after that generations of nuclear power stations were designed by upgradation in design and evolution of construction material as mentioned in Basu Prabir et al., 2013 and built worldwide by facing many challenges and accidents as mentioned by Kakodkar, 2014 and Lyerly and Mitchell, n.d. 1973. Containment structures are strong Shell-thick structures designed to withstand severe loading conditions and load combinations mentioned in International Atomic Energy Agency (IAEA) standards. In this standard a condition namely Design Extension Condition (DEC) is postulated, as it is a mandatory condition that a containment structure has to fulfil. It is very necessary to study the individual behaviour of each section and all individual materials, so that failure criteria of the material can be observed for monolithic action, then combined (Rebar + Concrete) action can be observed for better clarity, by means of Finite Element Method of Analysis.

As per AERB/SS/CSE Clause:3.5.2: Both classical method and Finite Element Method (FEM) for structural analysis are considered, the methodology and the software shall be validated in accordance with Cl.9.2.3 and 9.2.4 AERB SSG-53; SS/CSE; DNB

SSM 2015:25, and Furtherly, in IAEA Standard Provision, the requirements that to be fulfilled by containment structure is theoretically stated in several clauses.

Regarding containment structures, researchers have modelled containment structure and other components by FEM models as by Gasch T et al., 2018 and simple conventional models as in

Hong and Kang., 2016 and conducted FEA studies to observe deformations, stresses, strains and damage of containment by application of static and dynamic loadings. As mentioned in IAEA standards, the containment structure must be analysed for design pressures and earthquake load also similarly carried by Akbar et al., 1986 and in point of researchers the containments are analysed for failure pressure analysis Yan et al., 2019, where the ultimate potential of containment and critical points such as material strains are identified clearly as presented in Barbat et al., 1998.

The fragility nature of materials used in containment varies with respect to internal loading and pressure Jin et al., 2019, and Zhou et al., 2018. And, Shokohfar and Rahai, 2016 concluded that apart from internal loading temperature does have little amount of impact the ultimate behaviour of containment. The studies mentioned are related to failure and internal pressure analysis of containment structure. But as mentioned in introduction part, the containment models must be analysed and designed for Design Extension Condition loadings such as missile or aircraft impact. Bangash (b)., 2011 proceeded a conventional approach on aircraft impact on containment structure, providing displacements

and deformation of containment. The study was totally conventional, not enough finite element models were studied. It will be an availability on additional information of methodology for analysis and output parameters such as deformations, displacements and resultant output forces if models of containment are analysed by finite element method, as similar to above mentioned references.

So, in this Finite Element Analytical study of missile impact, the objective is to observe the deformation of thick PCC concrete wall and induction of bending pressure in PCC wall with its distribution during missile impact using ANSYS 2020 R1.

Finite element study contributes mathematical problem-solving support in various engineering fields with computer packages like ANSYS, ABAQUS, NASTRAN, HyperMesh etc., Finite Element Method of study is considered as approximate study depending upon category of analysis, size of the model involves processing of analysis and full model analysis will be useless Jiménez et al., 2021. This may be due to problematic approach towards any solution required. Results obtained from these studies can be verified by either manual calculations or experimental investigations. Many Finite Element studies has been proved to be correct, some are hypothetically correct and some are approximated result studies. It shows that other than conventional methods Finite Element Method is iterative in nature to approach any results or solutions of engineering problems.

1.1 DESIGN EXTENSION CONDITION

This condition has other sorts of impact loading and sudden loading actions on containment structure. Where Missile, Aircraft impacts are identified as high impact loads.

In 1988, the missile impact test on reinforced concrete has been experimentally carried out in Sandia National Laboratories, Washington DC, U.S. Other than missile impact, various scale models of containment were tested for static pressure, dynamic pressure and impact of Water slug, impact of Full scale F4 Phantom jet on thick RCC panel as shown in Fig 15. Though the publication of all the research experimental research work was published in "Containment Integrity Research at Sandia National Laboratories" An Overview - NUREG/CR-6906 SAND2006-2274P.

A Missile mass of 147 kg, with of velocity 13.1 m/sec; accelerated for impact on a Panel mass of 153 tones and thickness of 1.37m. A full-scale F4 Phantom jet was accelerated to 210 m/s (496 mph) to impact a ballistic pendulum, comprised of a 3.6 m (12 ft) thick reinforced concrete block on air bearings. This test was conducted for the Kobori Research

Complex, Tokyo, Japan. The purpose of the test was to measure the impulse of the aircraft impacting a rigid mass. The results of the test have been used to benchmark analytical models for aircraft loading time histories. In order to understand the full spectrum of loading conditions, Sandia National Laboratories conducted a series of impact tests for soft missiles on flexible targets. In these tests, a thin aluminum cylinder was filled with water, referred to as the 'water slug' and accelerated to impact a reinforced concrete panel. Tests were conducted varying the 'water slug' size and impact velocity. The results of these tests and the analyses conducted to simulate the tests were published in a limited distribution report.

This design extension condition like missile or aircraft impact can be conventionally calculated by finding missile impact force exerted on resting body by concept of Newton's 2nd law of motion, $F_{max} = m_o \times v_o$, where F_{max} is maximum force or pressure, m_o is the mass of moving body and v_o is the velocity of moving body. The inclination angle of missile during impact affects the magnitude of force induced during impact on containment Zhang et al., 2017. When the obtained maximum pressure is exceeding the prescribed pressure value of concrete, it is identified as damage or failure of concrete part where it is receiving impact of moving object. As this is a time depended event, location and magnitude of maximum force exerted on body must be tracked throughout the event, where this could be difficult in manual calculations, so by using Finite Element software, the location of maximum force or induced pressure can be identified throughout event, by color contour maps on body with pressure magnitude legends. This identification is very mandatory in nuclear design to avoid critical accidents and failure of structure, and to fulfill overall structural integrity and performance for total design life period.

2 ANALYSIS SETUP AND BOUNDARY CONDITIONS

From the actual containment model setup as shown in Fig 1, a Cut-down setup is developed, as it will be better comparison of simulation and experimental case study. Height of Wall panel is 5m and thickness of panel is 1.56m (Thickness of wall at joint section in containment). In any structure Joints are vulnerable points, as it may fail earlier than monolithic member. Wall is assigned as Fixed support ($U_x=U_y=U_z=0$) at back face, rest of section is set free for damage and movements. Material adopted for wall is M70 grade of concrete. Length of missile is assumed as 5m and diameter of missile is

300mm is accelerated at 200 m/s. Material adopted for missile is Steel-Alloy. Distance of the missile is not accounted, as in the initial condition the velocity of missile body is pre-defined as 200 m/s. Due to this, from any distance (nearer or farther to wall in 3D model) the missile may start to impact, its initial velocity will be 200 m/s. Cut-Down model setup of the wall and missile is shown in Fig.2.

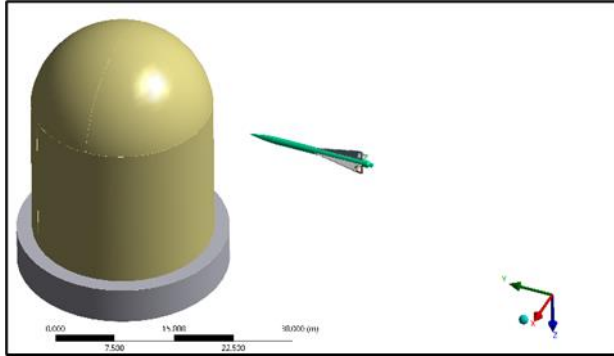

Fig 1. Actual Model setup

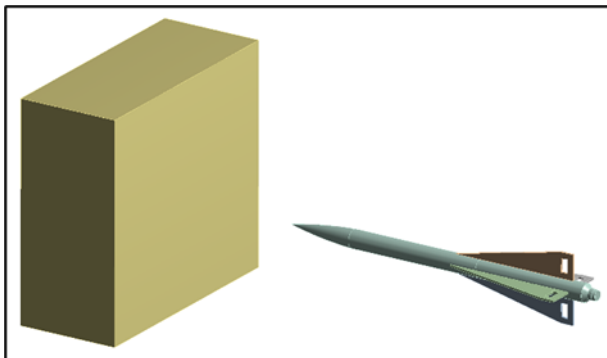

Fig.2 Cut-Down Model Setup

2.1 Results and Discussions

From the analysis, it is observed that, concrete part is getting severe damage and high surface pressures during impact, as wall is fixed, during impact it tries to bend, hence producing the bending pressure. The Induced bending pressure distribution is shown as color contours in Fig 3 to Fig 8 at 6 divided time frames and pressure values are tabulated in Table 1, pressure values plotted in Fig 9, bending pressure is at peak during initial time point, as the missile velocity will get reduced after the impact. As the wall is fixed back face, the global displacement is restrained, value observed is zero. Still computational performance is not high-end, Ansys Parametric Design Language cannot solve for damage of concrete. Pressure induced on wall due to impact of missile is observed throughout the event, with the obtained pressure values and contour pattern on wall, damage can be predicted by manual verification.

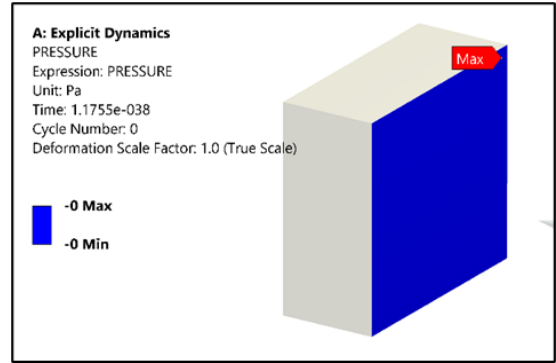

Fig 3. Pressure Distribution-1

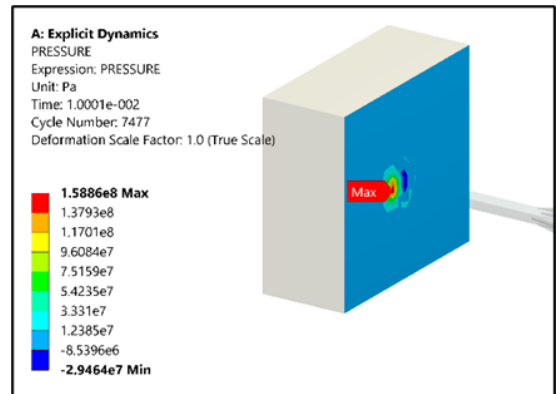

Fig 4. Pressure Distribution-2

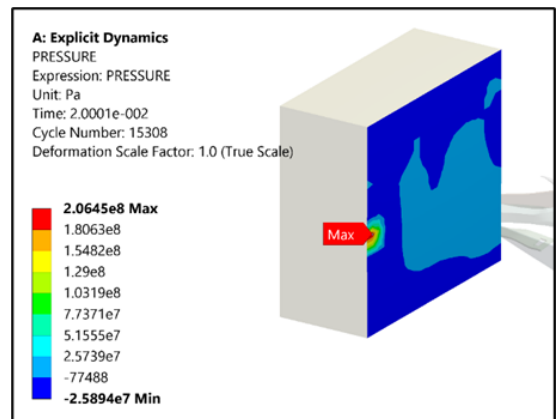

Fig 5. Pressure Distribution-3

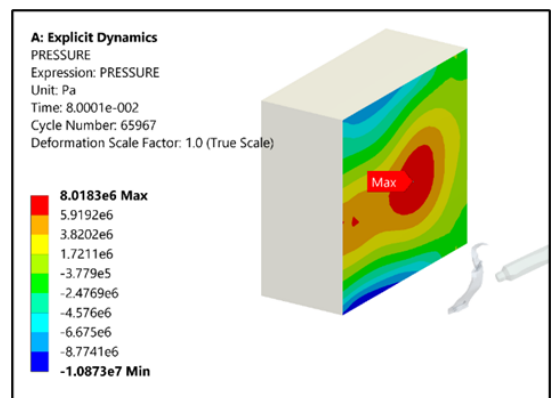

Fig 6. Pressure Distribution-4

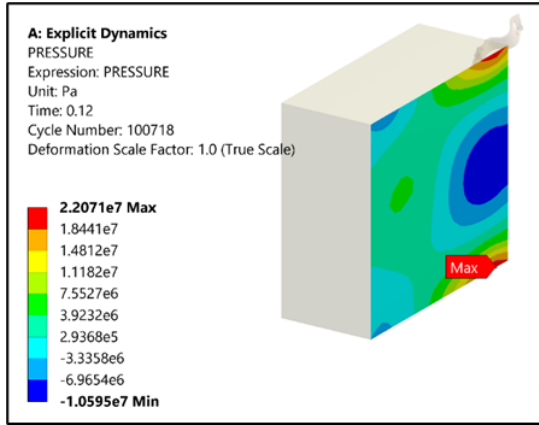

Fig 7. Pressure Distribution-5

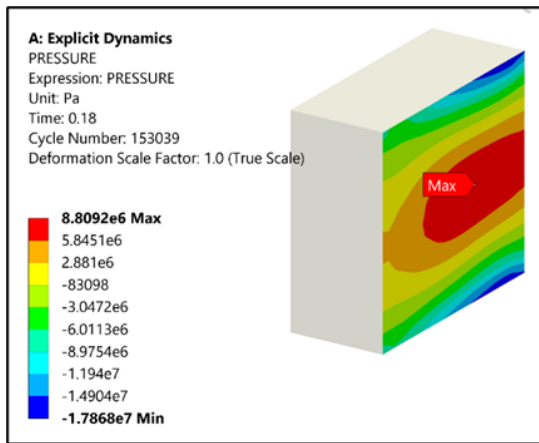

Fig 8. Pressure Distribution-6

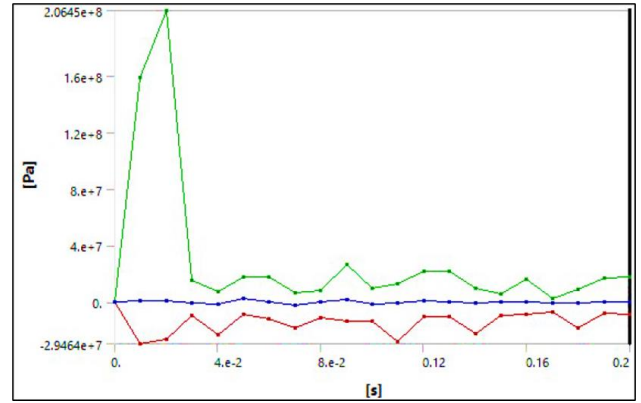

Fig 9. Pressure plot

In the Fig.10 the probe tracker shows the minimum and maximum pressure induced in concrete wall throughout the event. As the event is time depended, this probe tracks minimum and maximum bending pressure at each division throughout the section.

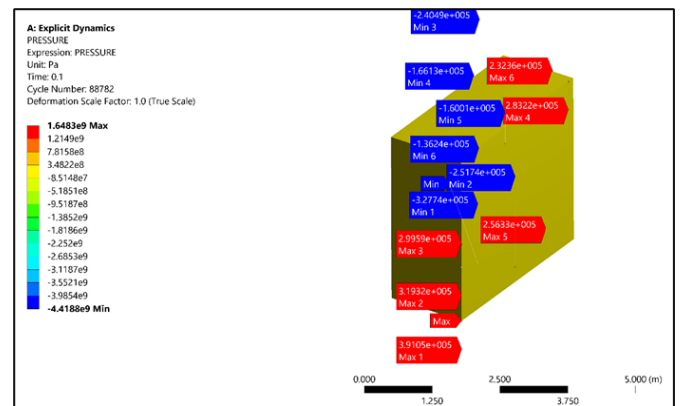

Fig 10. Probe tracking of bending pressure

Table 1 Induced Bending Pressure Distribution

Time [s]	Minimum [Pa]	Maximum [Pa]	Average [Pa]
1.2E-38	0.0E+00	0.0E+00	0.0E+00
1.0E-02	-2.9E+07	1.6E+08	6.8E+05
2.0E-02	-2.6E+07	2.1E+08	6.8E+05
3.0E-02	-9.8E+06	1.5E+07	-9.0E+05
4.0E-02	-2.3E+07	7.2E+06	-1.6E+06
5.0E-02	-8.4E+06	1.8E+07	2.3E+06
6.0E-02	-1.2E+07	1.8E+07	1.1E+05
7.0E-02	-1.9E+07	6.3E+06	-2.1E+06
8.0E-02	-1.1E+07	8.0E+06	5.5E+05
9.0E-02	-1.3E+07	2.7E+07	1.4E+06
1.0E-01	-1.3E+07	9.5E+06	-1.5E+06
1.1E-01	-2.8E+07	1.3E+07	-3.3E+05
1.2E-01	-1.1E+07	2.2E+07	1.0E+06
1.3E-01	-1.0E+07	2.2E+07	-1.5E+05
1.4E-01	-2.2E+07	9.6E+06	-9.4E+05
1.5E-01	-9.2E+06	5.8E+06	3.2E+05
1.6E-01	-8.3E+06	1.6E+07	6.2E+05
1.7E-01	-6.7E+06	2.4E+06	-7.4E+05
1.8E-01	-1.8E+07	8.8E+06	-2.4E+05
1.9E-01	-8.1E+06	1.7E+07	4.4E+05
2.0E-01	-8.5E+06	1.8E+07	6.9E+04

Missile is getting severe damage and deformation during impact as shown in Fig 11 to Fig 14. Inundation depth of missile is not known during this analysis, but in the Hessheimer et al., 2006 it has been reported that, during experimental investigation of F4 Phantom Jet impact on Thick RCC panel, inundation depth was 64mm (2.51inches), thereby the condition of remaining wall section was safe. No danger or warning situations were reported after impact.

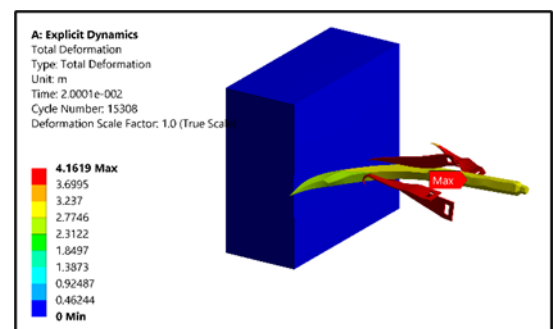

Fig 11. Missile Damage-1

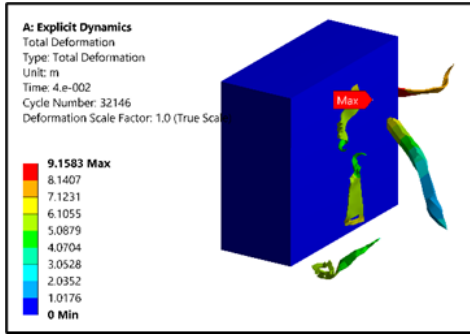

Fig 12. Missile Damage-2

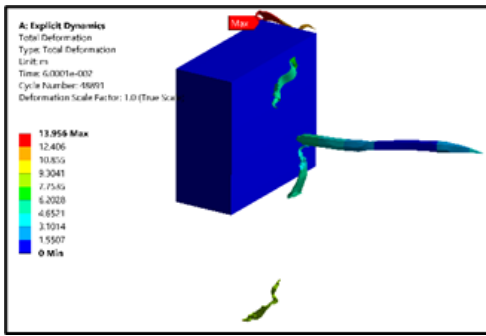

Fig 13. Missile Damage-3

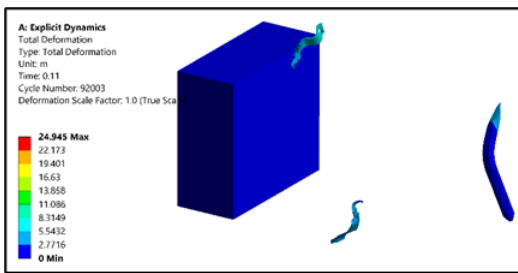

Fig 14. Missile Damage-4

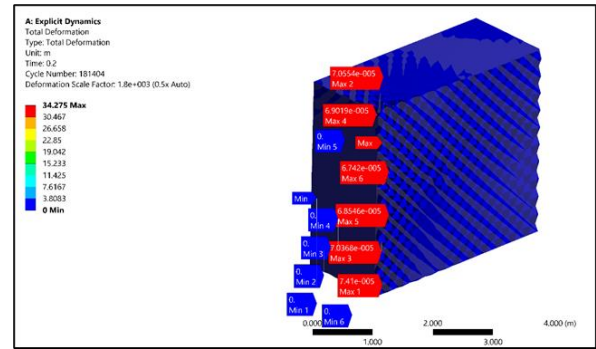

Fig 15. Shattered Deformation effect of concrete with probe

3 CONCLUSIONS

The cut-down FEA model setup for impact analysis is developed and analysed using ANSYS package, direct impact of missile body on thick PCC wall is carried out. Results show that, pressure induced in the concrete wall varies with respect to time and load. Pressure induced is bending type of pressure where for material M70 concrete, where the maximum pressure exceeds the ultimate pressure of material, that element part is considered to failure. Damage of concrete can be identified by manual verification with obtained pressure values, as this analysis was performed in a low-end device, the APDL solver was not able to perform damage of concrete computationally. Deformation of wall is visually observed as shattering effect of meshed parts, simulation is making understand that during impact concrete is subjected to this type (shattering) of deformation and damage.

4 REFERERNCES

- Basu, P., Labbe, P. and Naus, D., 2013. Nuclear power plant concrete structures.
- Gasch, T., Ahmed, L. and Malm, R., 2018. Instrumentation and Modelling of a Reactor Containment Building.
- Akbar, H., Gupta, A.K., 1986. Ultimate Behavior of an R.C. Nuclear Containment Subjected to Internal Pressure and Earthquake. *Journal of Structural Engineering* 112, 1280–1295. [https://doi.org/10.1061/\(ASCE\)0733-9445\(1986\)112:6\(1280\)](https://doi.org/10.1061/(ASCE)0733-9445(1986)112:6(1280))
- Bangash, M.Y.H., 2011b. Concrete Containment Subject to Aircraft Crashes and Seismic Effects and Over Pressurisation, in: *Structures for Nuclear Facilities*. Springer Berlin Heidelberg, Berlin, Heidelberg, pp. 451–494. https://doi.org/10.1007/978-3-642-12560-7_7
- Barbat, A.H., Cervera, M., Hanganu, A., Cirauqui, C., Oñate, E., 1998. Failure pressure evaluation of the containment building of a large dry nuclear power plant. *Nuclear Engineering and Design* 180, 251–270. [https://doi.org/10.1016/S0029-5493\(97\)00329-4](https://doi.org/10.1016/S0029-5493(97)00329-4)
- Hong, J.-K., Kang, T., n.d. Analysis of the Shell Structure under Extreme Load 11.

The induced pressure varies with respect to contact of missile body during impact, the pressure on concrete surface is observed changing with respect to time.

Here, the obtained is simulation is compared with real time experimental work, as mentioned in objective to accumulate the behaviour of Aluminum-alloy missile which is rigid in nature, getting high impact on high rigid PCC concrete panel. Fig.15 it is observed that meshed parts of concrete wall are shattered, it is the damage effect of concrete by showing the shattered deformation geometry during impact. As concrete wall is Rigid body, this shattered deformation effect is observed after scaling the result for multiple times. Probes showing Minimum and Maximum deformation of concrete wall in Fig.15

- Jiménez, S., Cornejo, A., Barbu, L.G., Barbat, A.H., Oller, S., 2021. Failure pressure analysis of a nuclear reactor prestressed concrete containment building. *Engineering Structures* 236, 112052. <https://doi.org/10.1016/j.engstruct.2021.112052>
- Jin, S., Li, Z., Lan, T., Gong, J., 2019. Fragility analysis of prestressed concrete containment under severe accident condition. *Annals of Nuclear Energy* 131, 242–256. <https://doi.org/10.1016/j.anucene.2019.03.034>
- Kakodkar, A., 2014. Evolution of nuclear reactor containments in India: Addressing the present day challenges. *Nuclear Engineering and Design* 269, 3–22. <https://doi.org/10.1016/j.nucengdes.2013.08.048>
- Lyerly, R.L. and Mitchell III, W., 1973. *Nuclear Power Plants (Rev.)*. US Atomic Energy Commission (AEC).
- Shokoohfar, A., Rahai, A., 2016. Nonlinear analysis of pre-stressed concrete containment vessel (PCCV) using the damage plasticity model. *Nuclear Engineering and Design* 298, 41–50. <https://doi.org/10.1016/j.nucengdes.2015.12.019>
- Yan, J., Lin, Y., Wang, Z., Fang, T., Ma, J., 2019. Failure mechanism of a prestressed concrete containment vessel in nuclear power plant subjected to accident internal pressure. *Annals of Nuclear Energy* 133, 610–622. <https://doi.org/10.1016/j.anucene.2019.07.013>
- Zhang, T., Wu, H., Fang, Q. and Huang, T., 2017. Numerical simulations of nuclear power plant containment subjected to aircraft impact. *Nuclear Engineering and Design*, 320, pp.207-221.
- Zhou, L., Li, J., Zhong, H., Lin, G., Li, Z., 2018. Fragility comparison analysis of CPR1000 PWR containment subjected to internal pressure. *Nuclear Engineering and Design* 330, 250–264. <https://doi.org/10.1016/j.nucengdes.2018.02.005>
- ATOMIC ENERGY REGULATORY BOARD
SAFETY STANDARD “Civil Engineering Structures Important to Safety of Nuclear Facilities” NO. AERB/SS/CSE, GOVERNMENT OF INDIA, Atomic Energy Regulatory Board Mumbai - 400 094
- Swedish Radiation Safety Authority “Design Guide for Nuclear Civil Structures (DNB)” SSM 2015:25, June 2015 Report number: 2015:25 ISSN: 2000-0456, www.stralsakerhetsmyndigheten.se
- Hessheimer, M. and Dameron, R., 2006. NU REG/CR-6906 SAND2006-2274P: Containment Integrity Research at Sandia National Laboratories. *An Overview*.