

Ultrasonic Signal Characteristics in Pre- and Post-yield Steel Structures

Y. Bingol

A.M. Okeil*

Louisiana State University, Baton Rouge, Louisiana, USA

**Email: aokeil@lsu.edu*

ABSTRACT: The theory of acoustoelasticity has been the main concept behind most studies investigating the stress level in different structural materials. In this paper, an alternative approach for stress assessment is investigated whereby signal characteristics are identified under different stress levels. The results of an experimental investigation on longitudinal waves propagating perpendicular to the applied stress are presented. Ultrasonic signals were acquired from steel specimens subjected to different uniaxial tensile stress levels. Two well known Digital Signal Processing (DSP) methods; the Fast Fourier Transform (FFT) and Chirp-Z Transform (CZT), were used to analyse the signals in the frequency domain. Two other techniques; peak amplitudes and signal energies, were used for investigating the acquired signals in the time domain. This study confirms that the acoustoelastic effects on ultrasonic signals are miniscule within the elastic range for longitudinal signals travelling perpendicular to the applied stress. However, the results show a clear distinction between signal characteristics prior to and post yielding.

1 INTRODUCTION

The Structural Health Monitoring (SHM) field has developed remarkably in the last few decades with the adaptation of new techniques and technologies. Several methods have been studied and introduced by researchers for assessing the structural integrity and safety of civil engineering structures (Chang & Liu 2003, Giurgiutiu & Cuc 2005). SHM methods are generally used for (1) validating the design assumptions to improve the design specifications for future use, (2) detecting anomalies and damages before and after disasters or extreme events to provide the necessary information for rehabilitation, and (3) monitoring the repairs to evaluate the effectiveness of the applied works (Ko & Ni 2005). There are many existing structures that are about to reach, or have already reached, the end of their design life. These structures first need to be identified and then prioritized for required repairing and strengthening actions. Thus, well-coordinated interdisciplinary research was motivated by the lack of an effective and a reliable tool that can fully achieve the aforementioned objectives (Ko & Ni 2005).

Non-destructive Testing (NDT) is a rapidly growing research area that has been offering solutions for health assessment of structures. Materials and structures can be tested with NDT methods without destroying their usefulness as opposed to destructive techniques, which are generally more expensive and

time consuming. With few exceptions, NDT in civil engineering has mostly been used: (i) to determine material properties (e.g. concrete compressive strength, water-cement ratio, modulus of elasticity, dynamic modulus and Poisson's ratio), (ii) to detect defects (e.g. cracks/voids), and (iii) to locate embedded reinforcement (e.g. steel bars and prestressing strands). In addition to the important tasks of identifying material properties and detecting damage, the determination of stress levels in structures is also important for structural condition assessment, especially for highly stressed zones.

The Theory of Acoustoelasticity explains the dependence of wave velocity on the stress state of the material through which it travels. It is the most widely used technique for stress measurement in structural materials. The theory was first introduced in 1953 (Hughes & Kelly 1953). The acoustoelastic constants were shown to be specific for different materials and to be translating the effect of a stress field to ultrasonic wave velocities (Egle & Bray 1976). Since the late 1950's, this theory has been used as a non-destructive method for measurement of the residual and applied stress levels of structural materials such as aluminium, steel and timber (Egle & Bray 1976, Duquennoy et al. 1999, Bergman & Shabbender 1958, Si-Chaib et al. 2001, Santos & Bray 2001, Sgalla & Vangi 2004). The linear relationship between the relative changes in the wave velocity and the stress state of the material was used

in all of these studies for stress measurement. The sensitivity of this linear relationship was investigated for various stress and wave directions (Egle & Bray 1976). Figure 1 illustrates three possible wave directions for an element under tension.

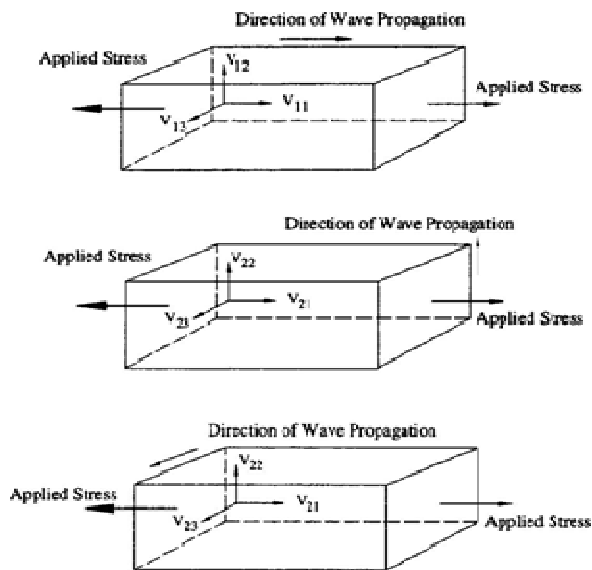

Figure 1. Possible orthogonal directions and designations of velocities in solids (Bray & Tang 2001).

The first and the second indices of the velocities in Figure 1 represent the propagation of the wave and the direction of the movement of the particles (polarization direction) respectively. The velocities which have the same direction of wave propagation and polarization correspond to longitudinal waves (e.g. V_{11} , V_{22}), meanwhile others represent the velocities in a perpendicular plane, known as shear waves (e.g. V_{12} , V_{13}).

The sensitivity of these waves to the material strain level is significantly affected by the polarization direction of the waves. As can be seen in Figure 2, the largest relative change in wave velocity is associated with longitudinal waves (V_{11}) followed by shear waves when particles vibrate parallel to the applied load (V_{21}). However, stress measurement with these two waves may not always be possible in practice where the placement of transducers for these velocities might not be practically possible. This is due to the fact that structures' ends may be inaccessible, and if they are, distances between access points are usually long. Furthermore, stress levels usually vary along a structure's length, which complicates the problem of identifying stress levels. Another important challenge is that the application of acoustoelasticity to measure the applied or residual stresses in terms of wave speed or time of flight (TOF) is not a reference-free technique since the distance between the source and the receiver of the ultrasonic wave needs to be known exactly (Junge et

al. 2006). Furthermore, the dependency of ultrasonic velocity with stress can be significantly non-linear for some materials (Mishakin et al. 2006). Therefore, stress measurement using longitudinal and shear waves, where the particles vibrate perpendicular to the load requires more effective methods as the sensitivity of these waves to the stress state of the material is not significant.

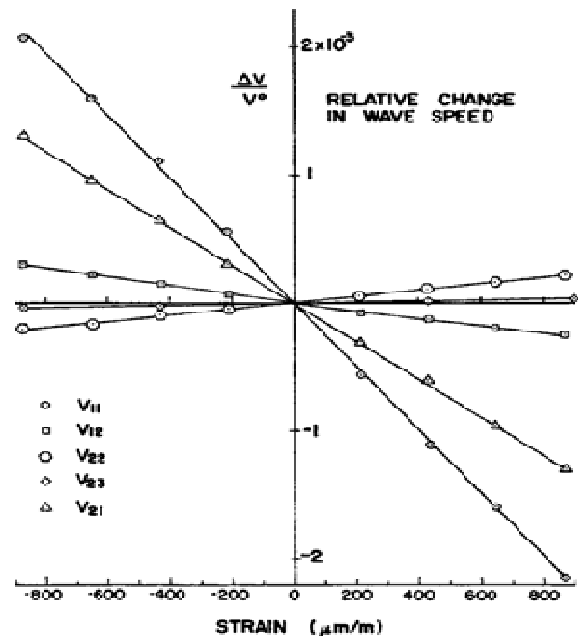

Figure 2. Sensitivity of longitudinal and shear waves to the strain (Egle & Bray 1976).

Instead of using the relative changes in the wave velocity, this paper investigates the dependence of four different parameters of ultrasonic signals in time and frequency domains on the stress state of steel. Ultrasonic longitudinal signals, travelling perpendicular to the load (V_{22} , based on the nomenclature in Figure 1), are acquired using a specially built testing system from steel specimens under uniaxial tension before and after yield under various stress levels. V_{22} was chosen in this study because it is the most likely velocity that can be acquired in the field from thin-walled steel structures because of accessibility issues. For the time domain analysis, the relationship of the applied stresses with the changes in the peak amplitudes and the signal energy values of the first three echoes of the acquired signals were investigated. The other two parameters are obtained using spectral analysis. The commonly used DSP techniques; namely the Fast Fourier Transform (FFT) and the Chirp-Z Transform, were used. All results were normalized with the values corresponding to the unstressed condition for eliminating the effect of different test settings. The dependence of the signal energy, time domain peak amplitudes, and FFT and CZT peak values on the stress level of the material are presented. The experimental results

show that the effect of the stress state on the investigated signal characteristics may be used to detect yield in steel.

2 EXPERIMENTAL PROGRAM

An experimental program was conducted to study ultrasonic signal characteristics before and after yield. The details of this program are described next.

2.1 Specimen preparation and properties

All specimens were obtained from a quarter of an inch thick ASTM A36 steel plate. The plate was cut by a hydrocut waterjet machine to obtain sheet-type test specimens. The specimens have the dimensions of the rectangular sheet-type standard specimens following ASTM Standard E8-04 (ASTM 2004). Three initial tests were conducted to obtain information about the material's mechanical properties in tension. For these tests, MTS 810 Hydraulic Materials Testing System was used, which was controlled by an MTS TestStar II controller that is programmed via a PC using MultiPurpose TestWare[®] software (Model 793.10). The software allows the user to customize and generate special test procedures and store the test data from three channels, namely; force, displacement and strain. Two different MTS extensometers with one and two inch gage lengths were used for acquiring strain data. The results of these three material tests showed that the yield strength of the material is 310MPa (45ksi) while the ultimate strength is 469MPa (68ksi). Figure 3 shows the stress strain relationship for the specimen material.

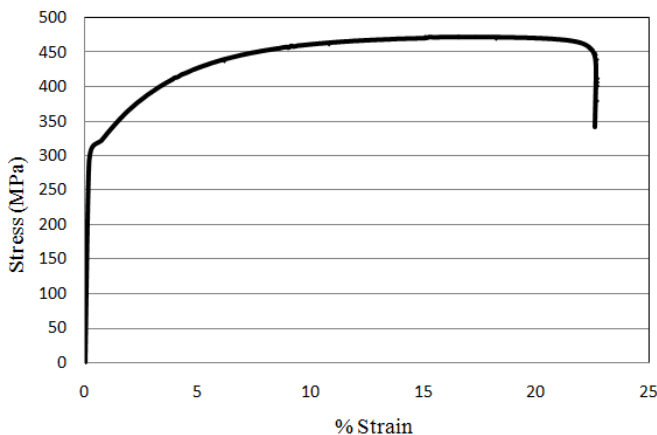

Figure 3. Stress-strain curve of steel used in this study.

2.2 Testing system

The testing system used for the experiments is composed of three main units in addition to the MTS

810 Testing System used for material tests. The core of the system is the Panametrics 5900PR pulser-receiver which is computer-controllable through GPIB IEEE488 or RS-232 communication ports and with a maximum bandwidth of 1 kHz – 200 MHz. The multi-position switchable high-pass and low-pass filters of the pulser-receiver were set to the lowest and the highest positions respectively during the ultrasonic measurements to disable filtering the signals with the device.

Ten MHz Panametrics longitudinal wave transducers (Model V112-RM) were used to transmit and receive the signals. These cylindrical shaped fingertip size contact transducers have a diameter of 9mm (0.35in) and a height of 11mm (0.42in). The transducers were attached to the mid-section of the specimens using a lightweight C-clamp (Figure 4) after Sonatech Inc.'s ultrasonic testing couplants (Ultragel II and SonoGlide[®]) were applied on the specimen's surface.

The last component of the testing system is a PC equipped with a digitizer board (Acqiris Model DP310) operating up to 420MS/s sampling rate, and MATLAB software. The received signals were digitized with 400MS/s sampling rate (2.5ns time steps) and stored in the computer to be used for subsequent signal processing applications. Figure 5 shows a schematic of the experimental setup instrumentation for the through-transmission measurement mode.

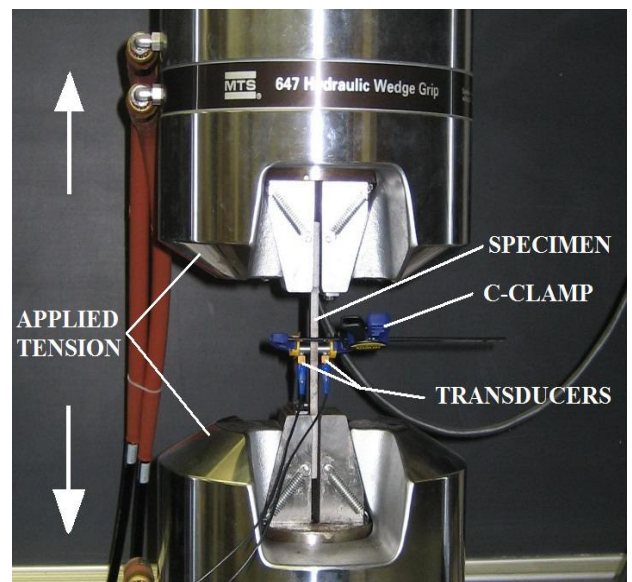

Figure 4. Configuration of transducers for through transmission operation mode.

2.3 Test database

Seven ultrasonic tests were conducted. The ultrasonic measurements were taken with the pulse-echo (P/E) mode for two of the seven tests where a single

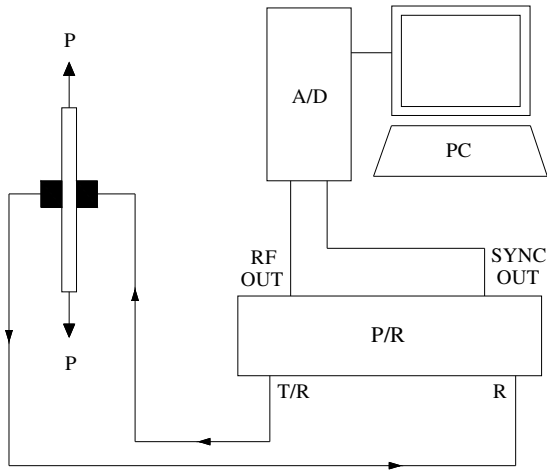

Figure 5. Experimental setup: P, applied tension force; T/R, transmitting transducer; R, receiving transducer; P/R, pulser/receiver; A/D, digitizer.

transmitter/receiver transducer is placed on one surface of the material and back surface echoes are received by the same transducer. The rest of the experiments were conducted with the through-transmission (TT) mode which is basically placing two transducers on opposite faces of the specimen. This mode results in an acquired signal where the back surface echoes are preceded by the main bang that directly reaches to the receiver transducer.

The first four of these tests were pilot tests where the specimens were loaded in the elastic region of the material (up to stress level, σ , equal to 276MPa ()). Signals were acquired at stress intervals, $\Delta\sigma$, of 69MPa (10ksi). Following the pilot tests, three specimens were tested up to failure and ultrasonic measurements were acquired before and after yield. A higher stress resolution (smaller stress increments) was chosen close to and beyond yield. Designation of tests and the stress levels where the ultrasonic measurement were taken are shown in Table 1. Results obtained from these tests formed the experimental database used in this study.

Table 1. Summary of tests and ultrasonic measurements.

Test #	Test Mode	Stress Levels of Ultrasonic Measurements
Test 1	TT	0, 69, 138, 207 and 276MPa
Test 2	TT	0, 69, 138, 207 and 276MPa
Test 3	P/E	0, 69, 138, 207 and 276MPa
Test 4	P/E	0, 69, 138, 207 and 276MPa
Test 5	TT	0,69,138,207,276,310,345,379,414,448 and 469MPa
Test 6	TT	0,69,138,207,276,310,345,379,414,448 and 469MPa
Test 7	TT	0, 69, 138, 207, 276, 293, 303, 310, 328, 345, 379, 414, 431, 448 and 469MPa
Test 8	TT	0, 69, 138, 207, 276, 293, 303, 310, 328, 345, 362, 379, 396, 414, 431 and 448MPa

3 ANALYSIS OF EXPERIMENTAL DATA

Most of the previous studies in ultrasonic NDT for stress measurement are based on acoustoelasticity where the main idea is measuring the variation in the time of flight of the ultrasonic wave through a material with a known thickness. Subsequently a relationship between the stress state and the wave velocity may be established. As was mentioned before, such a relationship is directly related to the type of ultrasonic wave (e.g. longitudinal or shear wave) and the direction of the particle vibration relatively to the direction of applied load. The use of longitudinal signals travelling perpendicular to the applied stress suffers from lower accuracy due to the fact that acoustoelastic effect is not as pronounced as it is in other directions (e.g. V_{11} in Figure 1). Thus, the current study investigates the acquired ultrasonic signals in terms of four different parameters in both time and frequency domains.

Before the digitized signals were analysed, a Moving Average Filter was utilized to remove the random noise. The moving average filter is a type of Finite Impulse Response (FIR) filters and it is one of the most commonly used filters in DSP due to its ease of use (Smith 2002). Moving average filters average a specified number of data points of the input signal and it are mathematically defined as:

$$y[i] = \frac{1}{M} \sum_{j=0}^{M-1} x[i+j] \quad (1)$$

where M is the number of points used in computing the moving average, $x[i]$ and $y[i]$ are the input and the output signals, respectively. An example of the acquired, digitized and filtered signal is shown in Figure 6a. Even though the figure demonstrates only the first three echoes, more were acquired and stored. However, only the first three echoes were investigated in this study due to the lower amplitudes and more noise of the following echoes.

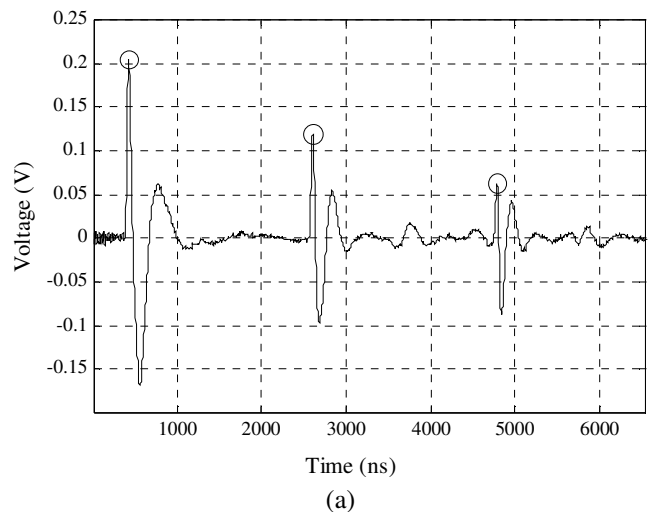

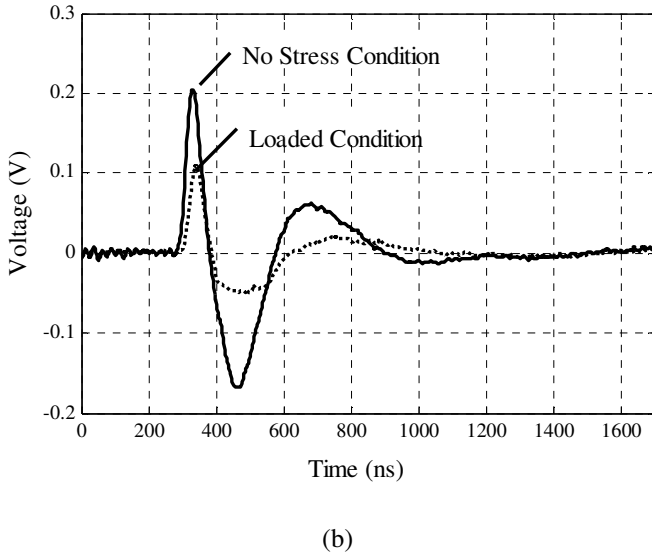

Figure 6. Acquired ultrasonic signals and the changes in the amplitude due to applied load [$\sigma = 379\text{MPa}$ (55 ksi)].

3.1 Time domain analysis

After the digitized signals were acquired and filtered under various stress levels, they were analysed in the time domain. First, the maximum positive peak amplitudes of the first three echoes for all stress levels (see Figure 6a) were analysed. The decrease in the amplitude, due to applied load, of the first back-surface echoes for the unloaded and for the 379MPa (55ksi) stress condition and are demonstrated in Figure 6b. Since different measurement settings and test conditions may affect the voltage of the acquired signals, all the peak values were normalized with the peak value corresponding to the unstressed (initial) condition of the set of data that was detected for the same echo under different stress states. The results from this and the other analysis methods are presented in Section 4.

In addition to the peak value analysis, calculation of the signal energies for the first three echoes was the second phase of time domain analysis. The signal energy for a digital signal is defined as:

$$E = \sum |x[i]|^2 \quad (2)$$

All signal energy values were also normalized with the initial (unstressed) value of energies calculated for the same echo under different stress levels.

3.2 Frequency domain analysis

Two well known DSP transformation techniques, the Fast Fourier Transform (FFT) and the Chirp-Z Transform (CZT) were used for the spectral analysis

of the signals. FFT is a powerful algorithm for implementing the Discrete Fourier Transform (DFT). It is frequently used by researchers and scientists in many fields including NDT in civil engineering. The DFT of a discrete sequence, $x(n)$, is:

$$X_k = \sum_{n=0}^{N-1} x(n)e^{-j(2\pi/N)nk} \quad k = 0, \dots, N-1 \quad (3)$$

The FFT algorithm implements the above equation of length N with a frequency resolution of $\Delta f = f_s/N$ where f_s is the fixed sampling frequency (Wang 1990). Therefore, to increase the frequency resolution with the FFT algorithm, N should be as large as practical (Daponte et al. 1995). At this point, using N as the closest power of two or zero padding becomes a disadvantage of FFT. Hence, this research investigated using the CZT for an increased frequency resolution without any zero padding (Nair et al. 1991).

The CZT of a sequence, $x(n)$, is given by:

$$X(z_k) = \sum_{n=0}^{N-1} x(n)z_k^{-n} = \sum_{n=0}^{N-1} x(n)A^{-n}W^{nk} \quad (4)$$

where $k = 0, 1, \dots, M-1$; M is an arbitrary integer; $n = 0, 1, \dots, N-1$; and A and W are complex numbers in the form of:

$$A = A_0 e^{(jw_0)} \quad \text{and} \quad W = W_0 e^{-j\Delta W_c} \quad (5)$$

The terms W_0 and ΔW_c are the starting angular frequency and the angular frequency increment in the z -plane, respectively. Since these numbers can be picked by the user of the algorithm, a bandwidth of interest in the frequency domain can be evaluated for any desired resolution. For ultrasonic signals, the bandwidth of interest is usually around the working frequency of the transducers where higher resolution than for the neighbouring ranges is desired (Daponte et al. 1995).

Figure 7 shows the FFT and the CZT of the third back-surface echo for the $\sigma = 345\text{MPa}$ (50ksi) stress level. Using these two DSP techniques, the first three echoes of the ultrasonic signals for every stress level were analysed in the frequency domain and their peak values were stored. To eliminate the effect of test settings and the attenuation in the second and the third back-surface echoes, similar to time domain analysis, every set of data for the peak values of FFT and CZT for the same echo, was normalized with the initial (unstressed) value of the data set.

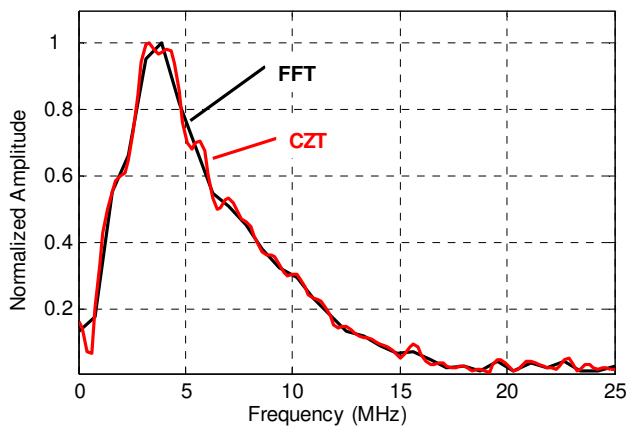

Figure 7. FFT and CZT of the third back-surface echo for 345MPa (50 ksi) stress.

4 EXPERIMENTAL RESULTS AND DISCUSSION

The results are presented in graphical form separately for the four different parameters considered in this study, namely; the peak amplitude, signal energy, FFT and CZT peak amplitudes. It should be noted that, the stress values in Table 1 are the target stress levels at which ultrasonic signals were planned to be acquired. However, the exact target stress levels were not always achievable because of the sensitivity of the testing system. Therefore, the actual stress values applied by the MTS testing machine were recorded during ultrasonic measurements and these exact values were used with the corresponding values for the graphical analysis of results. In addition to the normalization of the investigated parameters, the stress and strain values were also normalized with respect to the yield stress and yield strain values respectively that were obtained from the material tests.

The results of the time and frequency domain analysis for the peak amplitudes, signal energy, FFT and CZT are presented in Figures 8-11. The variations in the inspected parameters are shown with respect to the applied stress level as percentage of yield stress and the ratio of strain level to the yield strain level in logarithmic scale. Furthermore, all data sets were divided into three intervals. Two of these stress intervals correspond to stress levels below 90% (shown with red circle markers in figures) and above 110% of the yield strength (shown with yellow diamond markers in figures). The third interval was defined to be in between these two percentages; i.e. a transition interval (shown with blue triangle markers in figures).

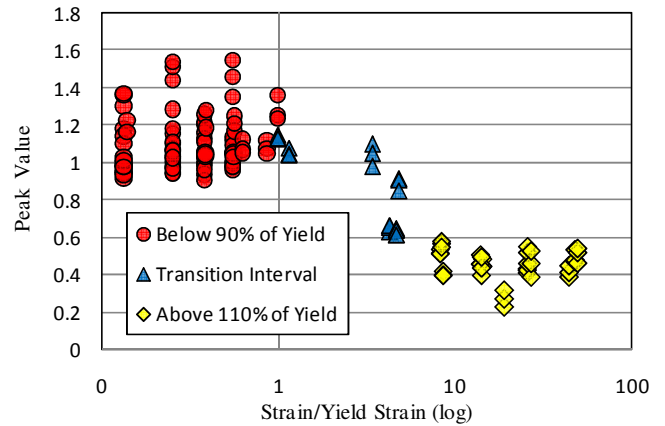
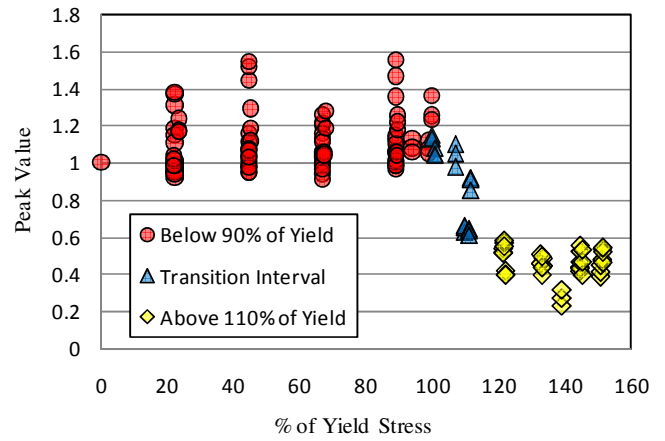

Figure 8. Results of time-domain analysis: Relationship of normalized peak amplitude with the stress state and strain level of steel.

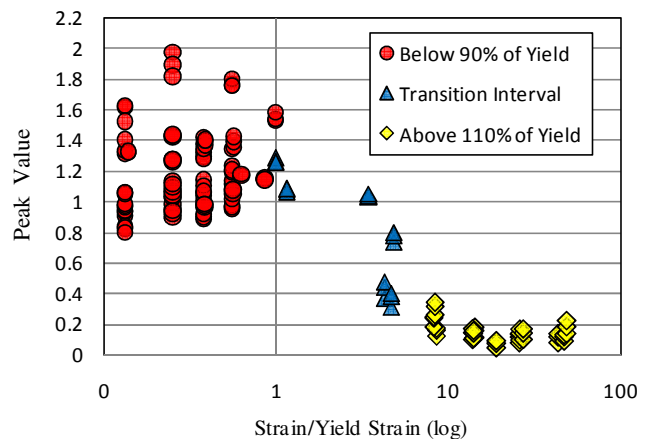
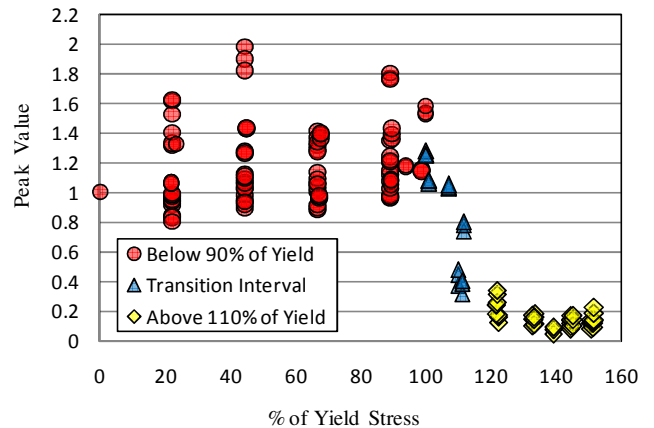

Figure 9. Results of time-domain analysis: Relationship of normalized signal energy with the stress state and strain level of steel.

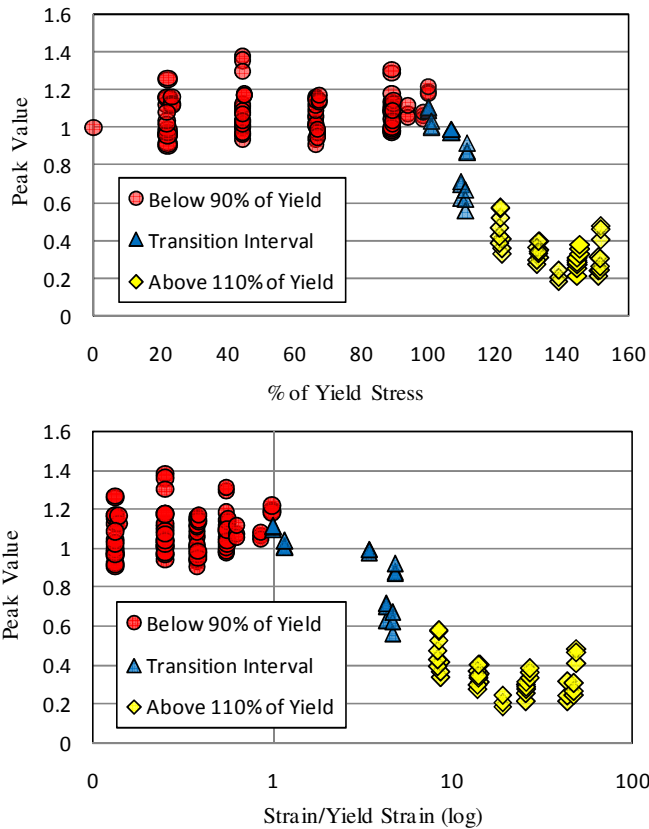

Figure 10. Results of frequency-domain analysis: Relationship of normalized FFT peaks with the stress state and strain level of steel.

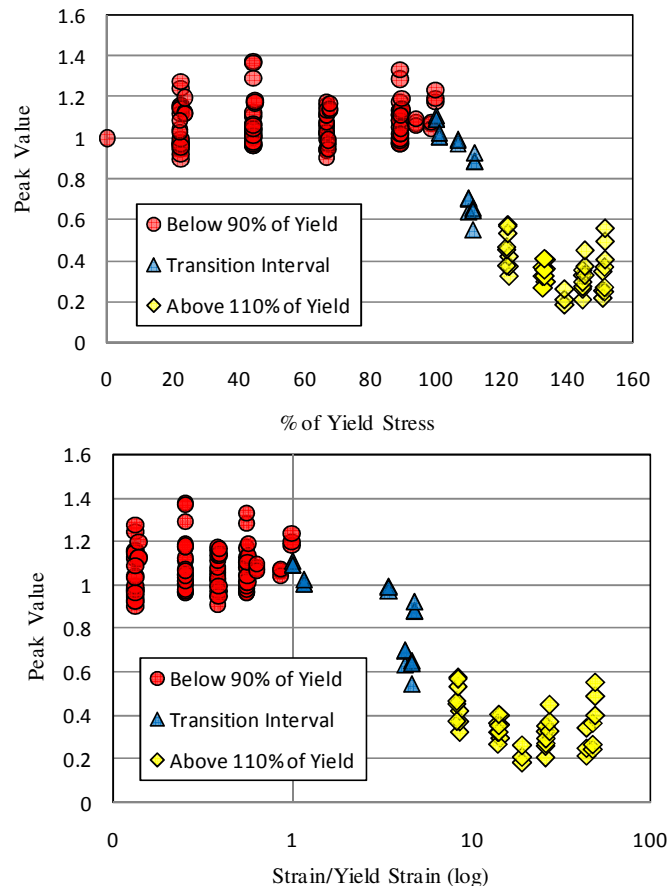

Figure 11. Results of frequency-domain analysis: Relationship of normalized CZT peaks with the stress state and strain level of steel.

The amplitudes of the acquired signals are very sensitive to several factors such as the tightening of the clamps and the amount of couplant used between the transducer and the specimen. A procedure was devised and strictly followed to minimize such unnecessary sources of uncertainty. The transducers were detached in between every ultrasonic measurement and then reattached using the same clamps and applying the same pressure level after replenishing the couplant between the transducer and the specimen. Nevertheless, even small changes in the initial data that is used for normalization cause the data to be scattered especially for the stress levels before yielding. The results of spectral analysis show relatively stable distribution at stress levels lower than the yield stress as compared to the results obtained from the time domain analyses. However, it can be seen from the results of both time and frequency domain analysis that a clear trend is observed for all parameters where the data points before yielding are scattered around and mostly above 1.0. Furthermore, the normalized values in this first stress interval are not below 0.9 for peak amplitude, FFT and CZT peaks and 0.8 for signal energy parameters.

In contrast to the first stress interval, the figures for all investigated parameters correlate in the transition interval, where the normalized values show a decreasing trend. This drop is down to 0.4 for normalized signal energies while it is around 0.6 for other methods.

The sudden decrease in the transition interval is followed by a relatively stable behaviour until failure where the data values are concentrated below a certain threshold for all methods. The results show that all the normalized data points in this final interval are smaller than 0.6 for the signal amplitude, FFT and CZT peak value methods whereas the upper limit for the signal energy method was found to be equal to 0.4.

A statistical analysis of the repeatability of the results was performed for all four investigated parameters. The data points corresponding to the three stress intervals were analysed by obtaining the statistical descriptors, mean and standard deviation, for all four methods. The results from the statistical analysis are presented in Table 2.

The results in Table 2 support the aforementioned observation about the existence of a clear threshold under which it may be said that the material has yielded. It also shows that the spectral analyses (FFT and CZT) result in lower standard deviations compared to time-domain parameters

Table 2. Statistical descriptors for the three stress intervals.

Investigated Method	Statistical Parameters	Stress Interval (% of Yield Stress)		
		≤ 90%	90% < < 110%	≥ 110%
Peak Amplitude	Mean	1.084	1.114	0.509
	Std. Dev.	0.139	0.092	0.135
Signal Energy	Mean	1.154	1.207	0.219
	Std. Dev.	0.248	0.173	0.176
FFT Peak	Mean	1.059	1.075	0.417
	Std. Dev.	0.099	0.070	0.183
CZT Peak	Mean	1.060	1.073	0.426
	Std. Dev.	0.099	0.073	0.182

within the elastic range. It can be seen that the standard deviation values of peak amplitude method for the transition and final intervals are lower than those for all other methods. However, the intensity of the decrease in the mean values after yield should be considered as the main criteria for determining the best method for yield detection. By studying the results for the final stress interval (above 110% of yield strength), it can be said that the normalized signal energy method results in a larger decrease compared to the other three methods. Moreover, the standard deviation for this technique is lower than the ones for spectral analysis for the final stress interval. Therefore, even though all investigated methods show great potential as a yield detection technique, it is clear that the signal energy method has greater potential for yield detection in steel structures than other methods.

5 CONCLUSIONS

High localized stresses are likely to occur in steel structures at critical sections and in the presence of crack-like geometrical conditions (Connor et al. 2007). This might result in the occurrence of stresses above the yield strength of the material at these critical locations and might lead to costly failures if not identified and treated with the necessary retrofitting strategies.

The dependences of four different time and frequency domain ultrasonic signal parameters on the stress state of steel were investigated. ASTM A36 plate type steel specimens were tested under uniaxial tension. Ultrasonic longitudinal signals travelling perpendicular to the applied load were acquired under different stress conditions with a specially built NDT system. Only the first three echoes of the signals were analysed as the following echoes contained relatively more noise for high stress conditions. Investigations in the time domain included studying the peak positive amplitudes and signal energies, while the Fast Fourier Transform (FFT) and

Chirp-Z Transform (CZT) were used for spectral analyses.

The obtained data were normalized with the initial unstressed value of every data set of the same echo. The statistical descriptors of uncertainty (mean and standard deviation) were calculated after dividing the data into three stress intervals chosen with respect to the yield stress of the material. Sudden decreases in the normalized parameter values were observed for all four methods at stress levels that are above yield whereas the data are mostly unchanged within the elastic region of the material. Despite the weakness of acoustoelasticity in prediction of stresses for the presented test setup, all four parameters analysed in this paper showed high potential for being used as an ultrasonic non-destructive yield detection technique for steel structures. The method can be used in practice by obtaining a reference data set from an unstressed dummy specimen under no applied stress and normalizing the data for the stressed conditions with this value. The presented methods will be improved and verified for different conditions (e.g. different thicknesses of specimens, temperature conditions, and surface roughness) in future research so that it can serve practitioners more accurately in investigating high stress localizations in steel structures.

6 ACKNOWLEDGEMENT

This material is based upon work supported in part by the Louisiana Board of Regents (RCS 2004-049A). Additional support from Louisiana State University is also acknowledged. Any opinions, findings, and conclusions or recommendations expressed in this material are those of the authors and do not necessarily reflect the views of the sponsoring agencies.

REFERENCES

- [1] ASTM E8-04: Standard Test Methods for Tension Testing of Metallic Materials. ASTM International, West Conshohocken, PA, 2004.
- [2] Bergman, R.M., and Shahbender R.A., "Effect of statically applied stresses on the velocity of propagation of ultrasonic waves", *Journal of Applied Physics*, Vol.29, 1958, pp.1736-1738.
- [3] Bray, D.E., and Tang, W., "Subsurface stress evaluation in steel plates and bars using the LCR ultrasonic wave", *Nuclear Engineering and Design*, Vol.207, No.2, 2001, pp.231-240.
- [4] Chang, P.C., and Liu, S.C., "Recent research in non-destructive evaluation of civil infrastructures", *Journal of Materials in Civil Engineering*, Vol.15, No.3, 2003, pp.298-304.
- [5] Connor, R. J., Kaufmann, E. J., Fisher, J. W., and Wright, W. J., "Prevention and mitigation strategies to address re-

- cent brittle fractures in steel bridges", *Journal of Bridge Engineering*, Vol.12, No.2 March/April 2007, pp.164-173.
- [6] Daponte, P., Maceri, F., and Olivoto, R. S., "Ultrasonic signal-processing techniques for the measurement of damage growth in structural materials", *IEEE Transactions on Instrumentation and Measurement*, Vol.44, No.6, 1995, pp.1003-1008.
- [7] Duquennoy, M., Ouaftouh, M., Ourak, M., and Xu, W.-J., "Influence of natural and initial acoustoelastic coefficients on residual stress evaluation: Theory and experiment", *Journal of Applied Physics*, Vol.86, No.5, 1999, pp.2490-2498.
- [8] Egle, D.M., and Bray, D.E., "Measurement of acoustoelastic and third-order elastic constants for rail steel", *Journal of the Acoustical Society of America*, Vol.60, No.3, 1976, pp.741-745.
- [9] Giurgiutiu, V., Cuc, A., "Embedded non-destructive evaluation for structural health monitoring, damage detection, and failure prevention", *The Shock and Vibration Digest*, Vol.37, No.2, 2005, pp.83-105.
- [10] Hughes, D.S., and Kelly, J.L., "Second-order elastic deformation of solids", *Physical Review*, Vol.92, No.5, 1953, pp.1145-1149.
- [11] Junge, M., Qu, J., and Jacobs, L. J., "Relationship between Rayleigh wave polarization and the state of stress", *Journal of Ultrasonics*, Vol.44, No.3, July 2006, pp.233-237.
- [12] Ko, J.M., and Ni, Y.Q., "Technology developments in structural health monitoring of large-scale bridges", *Engineering Structures*, Vol.27, No.12, 2005, pp.1715-1725.
- [13] Mishakin, V.V., Dixon, S., and Potter, M.D.G., "The use of wide band ultrasonic signals to estimate the stress condition of material", *Journal of Physics D: Applied Physics*, Vol.39, No.21, 2006, pp.4681-4687.
- [14] Nair, V. K., Ludwig, R., and Anastasi, R. F., "The Chirp-Z transform applied to adhesively bonded structures", *IEEE Transactions on Instrumentation and Measurement*, Vol.40, No.4, 1991, pp.751-758.
- [15] Santos, A.A., and Bray, D.E., "Ultrasonic stress measurement using PC based commercial flaw detectors", *Review of Scientific Instruments*, Vol.71, No.9, 2000, pp.3464-3469.
- [16] Sgalla, M., and Vangi, D., "A device for measuring the velocity of ultrasonic waves: An application to stress analysis", *Experimental Mechanics*, Vol.44, No.1, 2004, pp.85-90.
- [17] Si-Chaib, M.O., Menad, S., Djelouah, H., and Bocquet, M., "An ultrasonic method for acoustoelastic evaluation of simple bending stresses", *NDE&T International*, Vol.34, No.8, 2001, pp.521-529.
- [18] Smith, S., *Digital Signal Processing: A Practical Guide for Engineers and Scientists*. Newnes, 2002.
- [19] Wang, T. T., "The segmented chirp-z transform and its application in spectrum analysis", *IEEE Transactions on Instrumentation and Measurement*, Vol.39, No.2, 1990, pp.318-323.