

Experimental Study of Link Quality Distribution in Sensor Network Deployment for Building Environment

Malka. N. Halgamuge*

Toong-Khuan Chan

Priyan Mendis

University of Melbourne, Australia

*Email: malka.nisha@unimelb.edu.au

ABSTRACT: Monitoring and automatic control of building environment is a crucial application of wireless sensor network (WSN) in which maximizing network lifetime is a key challenge. The link quality distribution in a single floor of an indoor building environment is investigated experimentally to obtain a full coverage map. The results indicate a broad transitional region between 15 to 30m from the hub, and confirm that the transitional region is of particular concern in wireless sensor network since it accommodates high variance unreliable links. The poor link quality in the transitional region may be attributed to the many obstacles within the radio path including concrete element, brick walls, plasterboard partitions, office furniture and other items that either absorbs or reflects these radio waves leading to signal loss or multi-path effects.

1 INTRODUCTION

Environmental monitoring is considered as one of the principle applications for sensor networks today (Schmid (2006)). One of the earliest known environmental applications of sensor networks is in ecological habitat monitoring. A team from University of California Berkeley (Mainwaring et.al (2002), Szewczyk et.al (2004a) Szewczyk et.al (2004b)), utilised a wireless sensor network to observe birds on an island, using a base station connected over the web via a satellite communication link. This kind of “unattended” monitoring minimizes disruption to the objects of study by an observer walking around the island to collect data.

A sensor network is a computer network of many, spatially distributed devices using sensors to monitor environmental parameters such as temperature, sound, vibration, pressure, motion or pollutants at different locations. These devices are usually small and inexpensive, so that they can be produced and deployed in large numbers, and their resources in terms of energy, memory, computational speed and bandwidth are severely constrained. Various research problems of sensor networks such as data aggregation or fusion (Boulis et.al (2003), Cayirci (2003)), packet size optimisation (Sankarasubramanian et.al (2003)), cluster formation (Halgamuge et.al (2003), Halgamuge (2003)), target localisation (Zou and Chakrabarty (2003)), battery management (Halgamuge (2007)), network protocols (Heinzelman and Chandrakasan (2002), Intanagonwiwat et.al

(2000), Ye et.al (2002)) are discussed in the literature with respect to crucial energy limitations.

Halgamuge (2007) investigated efficient battery management for sensor life and reported guidelines for efficient and reliable sensor network design (Halgamuge et.al (2009)). Commercial radio technology has advanced and commercial standards such as Bluetooth, developed by the Bluetooth (2009) consortium, have started to appear. Ad hoc networks have been gaining popularity for military, space, biomedical and manufacturing applications in recent years because their easy deployment and lack of infrastructure requirements. Unlike cellular wireless networks, ad hoc wireless networks do not need any fixed communication infrastructure. Three main networking protocols are known in wireless communications: direct communication, multi-hop communication and clustering. The routes can be single or multi-hop and the nodes which may be heterogeneous and communicate via packet radio.

The heterogeneity of the nodes would allow some nodes to be servers and others to be clients. The ability of an ad hoc node to act as a server or service provider will depend on its energy, memory and computational capacities. Each node should estimate its own battery life before committing to a task. Even relaying packets for others may result in deteriorating its own limited battery power, and the node may not accept the task when it is devoted to another important activity.

There is a fundamental, incompatible feature between computer simulation and experimental evalua-

tion of sensor networks. On one hand, computer simulations provide complete control and transparent into experiments, but, on the other hand, they cannot reproduce, trustworthy, all the parameters that affect a live system (Schmid (2006)). In this paper, an experimental study was conducted to investigate link quality distribution in sensor network deployment for an indoor building environment. This experiment will leverage queries in real sensor network and also will drive development of network architecture. Both man-made hazards such as crime and terrorism as well as natural hazards such as earthquakes, tsunamis and winds can cause serious damage to buildings. Sensor networks can be effectively used to reduce the impact of such hazards through early detection and continuous monitoring. Therefore, monitoring and automatic control of the built environment has evolved into a crucial application of wireless sensor networks (WSN) in which maximizing network lifetime is a key challenge. The link quality distribution is investigated to obtain full coverage of signal strength in a single floor of a multi-storey office building, experimentally. The results indicated that the transitional region is of particular concern in the wireless network since it accommodates high variance unreliable links. The reason due to this transitional region in indoor environments could be due to various obstacles including concrete/brick walls, partitions, office furniture and other items effectively acting as additional absorption term to the path loss.

1.1 Sensor node

Sensor networks consist of many sensor nodes that can be deployed in random positions. Sensor components include:

- (a) flash memory: to store sensed data,
- (b) light sensor: a resistive light sensor to measure the intensity of ambient light. This sensor is turned off during sleep mode.
- (c) temperature sensor,
- (d) voltage regulator: a low drop-out voltage regulator to supply a constant 3.3 V from the batteries,
- (e) LED: a light emitting diode is used as a status indicator. This is turned on when the radio transceiver module is in active mode and turned off during sleep mode.
- (f) radio transceiver module: a Cypress 2.4 GHz DSSS
- (g) micro-controller: an ATmega168, 7.4 MHz processor with 16K byte RAM, 8 channel, 10 bit analog-digital-converter (ADC),
- (h) memory: random access memory, read-only memory includes both program memory (processor's instructions are executed) and data

memory (to store raw data and process sensor measurements)

- (i) power source: both wired and wireless options are open here for flexible deployment.

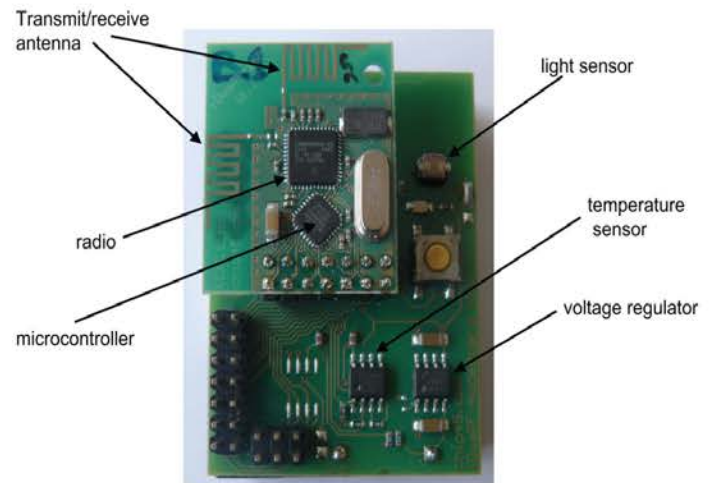

Figure 1. Sensor node showing the microcontroller, radio and on-board sensors

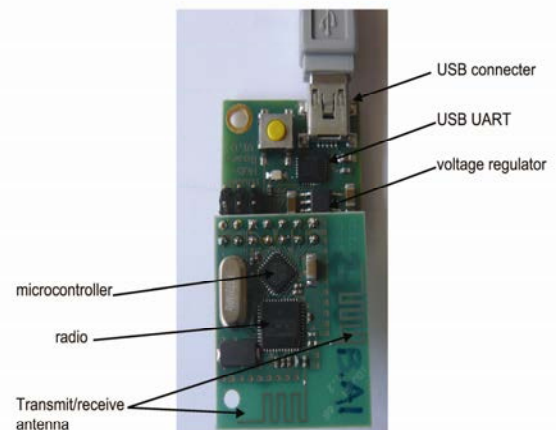

Figure 2. Hub node

1.2 Hub or base station

In these experiments, the hub forwards data packets it receives from sensor nodes to a base computer. The hub consists of the same micro-controller and radio module with an additional USB to UART converter.

Although the hub node has significant processing capabilities, all the data received were forwarded to computer through USB UART for further processing.

1.3 Duty cycle

A sensor node will generally be asleep during idle mode and wake up for duration of T_A as in Figure 3 and then sleep for T_S , assuming that $T_S \gg T_A$. The

duty cycle for the sensor node, d_N , can be defined by Mille et.al (2005) as:

$$d_N = \frac{T_A}{T_A + T_S} \quad (1)$$

Each sensor wakes up for duration T_A , senses data and listens to the appropriate radio channel. If the radio channel is free, transmit the data and go back to sleep for duration T_S . During the wake time, there is a fixed period for data measurement, but radio time varies according to the channel availability. Therefore in this series of experiments, total wake time is not fixed but dependent on radio traffic.

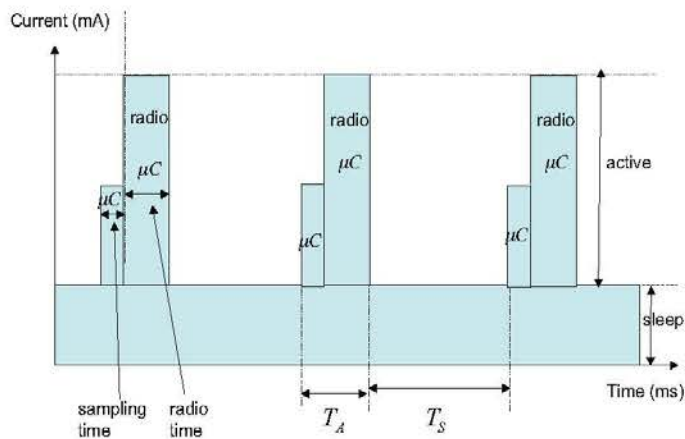

Figure 3. Wake-up and sleep time (duty cycle) for a sensor node.

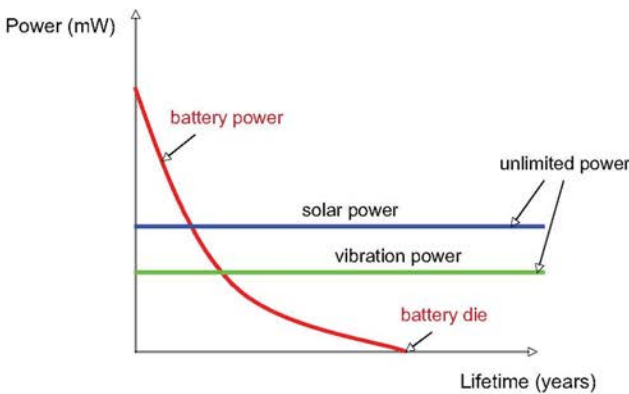

Figure 4. Different power sources versus lifetime.

Both solar power and vibration are promising methods of power scavenging as they offer relatively high power densities (Roundy (2003)). As opposed to batteries that have a limited life, both solar and vibrations based power harvesting methods have unlimited life as shown in Figure 4. The use of environmental energy to power wireless sensor networks has been proposed in numerous studies (Kansal et.al (2004), Roundy et.al (2003), Zhang et.al (2003), Balakrishnan et.al (2003), Jiang et.al (2005), Amirtharajah et.al (2005), Paradiso and Starner

(2005), Rahimi et.al (2003), Kansal and Srivastava (2003)).

2 WIRELESS LINK QUALITY AND DATA ACCESS RATE

Krishnamachari (2005), Zhao and Govindran (2003) and Lee et.al (2004) have conducted experimental studies of link quality in wireless sensor networks. There is no realistic model to show how data reception rate varies with communication distance. This combines both the radio propagation model and radio reception model. It is clear that data from high powered transmitters can be successfully received even with simultaneous traffic (Krishnamachari (2005)). However, energy cost for radio transmission, reception and idle listening is quite challenging.

It is well known that a contour formed by reception at different locations from the same transmitter is not regular. The quality of the transmission link distribution with and without power control is extremely dependent on environment and individual hardware conditions (Krishnamachari (2005)). For example, indoor office environments show poorer link quality distribution than open-space outdoor settings. Swapping transmitter and receiver locations can sometimes change the link quality. Krishnamachari (2005) proposed three regions of link quality:

- (a) *connected* region – high data reception rate (> 99%),
- (b) *transitional* region – data reception rate is vary, referred to as a gray area, and
- (c) *disconnected* region – very low data reception rate.

In region 1, data reception rate is highly reliable over time. In the transitional region, there can be very good link quality although transmit and receive antennas are relatively distant, as well as poor link quality, regardless of the relative proximity of the antennas. In this same transition region, many asymmetric radio links (high link quality in one direction and low link quality in the opposite direction) exist. There is high time variation in the link quality in the transition region. The width of the transitional region can be quite significant as a fraction of the connected area. Generally in free space the transitional region is much narrower whereas in an indoor environment, the transitional region could be enlarged due to the many obstacles, such as, office furniture, room partitions and concrete/brick walls.

3 EXPERIMENTAL SETUP AND NETWORK CONFIGURATION

The aim here is to investigate and map the link quality distribution in an indoor building environment. A simple wireless sensor network is deployed in an indoor office building with concrete floors, brick walls and plasterboard internal partitions. The iDwaRF sensor nodes were procured from www.chip45.com (2009). The nodes were powered with standard alkaline batteries. Temperature and light sensors which were pre-mounted on the sensor boards were utilized to measure the ambient conditions.

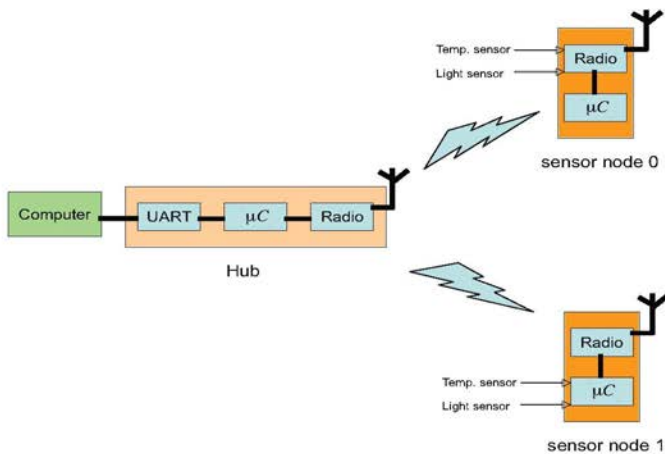

Figure 5. Experimental setup – each sensor node senses temperature and light and communicates with the hub via an N-to-1 star network.

The voltage is regulated to a constant 3.3 V. Each sensor node reports measurements once every second except for nodes at location A and B which were

sampling at 60 second intervals. The channel bandwidth is 10–100 kb/s and each single packet size was of 17 bytes. A sleep time of $T_S = 1000$ ms, and a wakeup time of $T_A = 22$ ms, were programmed for each sensor node. Active time depends on sampling and radio time. The sampling time is fixed, but radio time is dependent on channel availability. The sensor nodes sense data every t time period. The hub broadcasts channel availability in response to sensor node queries. Each sensor mode listens to a channel, and if it finds a free channel, it then transmits data packets to the hub and goes back to sleep. When the hub receives a data packet from the sensor node, it sends out an acknowledgement to the sensor node. The data packets are not processed locally at the hub but automatically forwarded to a computer for processing; therefore reducing sensor energy consumption.

The layout plan of the building as shown in Figure 6 indicates that the target floor area consists mainly of partitions which were “permeable” to radio waves and a number of brick walls which were “opaque” and very unfavourable in terms of radio propagation. The nodes were programmed to operate in an N-to-1 star network where each node was in direct two-way communication with the hub in order to determine the efficiency of the bi-directional radio communication. Two sensor nodes were deployed at a total of 15 locations (A–O) for a period of at least 60 minutes at each location, during this preliminary investigation. The data interval was nominally set at 1 second to obtain a large number of readings for each location.

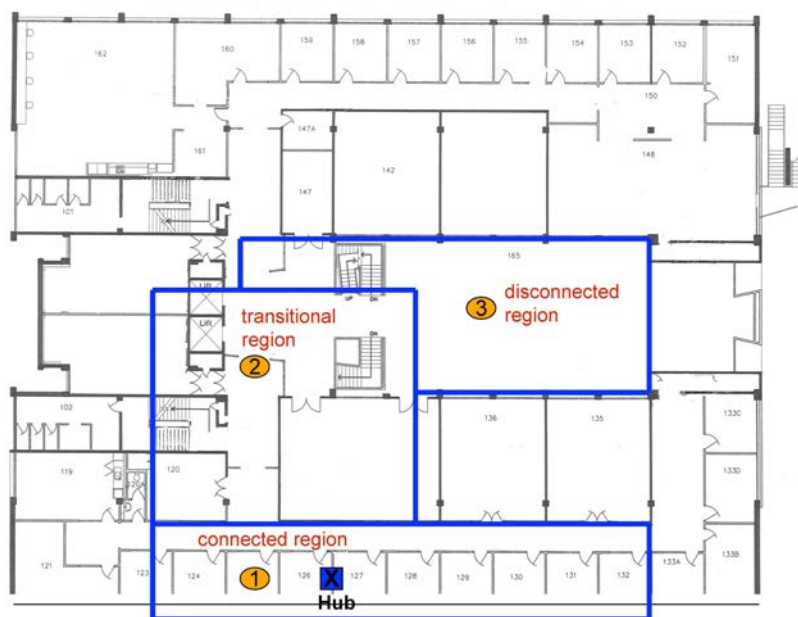

Figure 6. Deployed area of sensor network in the second floor of the Architecture Building at the University of Melbourne (solid brick walls are shown as bold black lines).

4 RESULTS AND DISCUSSION

4.1 Sensor readings

The recorded indoor air temperature profile at node location C for 24 hours is shown in Figure 8. It was observed that the temperature in a non-thermally controlled room increased from approximately 24°C at night to a high of 27.5°C during the day. The availability of high resolution temperature data is a significant improvement over many existing monitoring systems. Further work on optimising built environment control strategies will continue to require the use of these temperature sensors.

Figures 9 and 10 show the light profile at two separate rooms: location A was with natural lighting whereas location C was supplemented with artificial lighting. It can be observed that the natural

light level fluctuated significantly at location A between 7.00 and 10.00am on December 30. The room with artificial lighting exhibited a constant light level between 9.00am and 4.00pm. This light intensity data can be used as the basis for providing additional lighting, and to determine the duration and intensity of supplemental lighting, if necessary. Incidentally, the light sensor picked up the entry of the cleaners into location C at 12:23am. According to the data shown in Figure 11 the battery voltage decreases between December 26 and 27. This result is dependent on the transmission distance and other sources of energy consumption such as sensing, processing, and logging on the sensor node. However, energy dissipation for communication becomes more and more dominant as the distance between the node and hub increases.

Table 1. Data packet received, re-transmitted and lost.

Location	Expected data	Received data	Re-transmit	Useful data	Lost data	Re-transmit (%)	Useful data (%)	Lost data (%)	Radio distance (m)
A	1424	1424	0	1424	0	0.00	100.00	0.00	1.8
B	1423	1423	0	1423	0	0.00	100.00	0.00	3.0
C	17053	17285	238	17047	6	1.40	99.96	0.04	21.2
D	17053	17156	113	17043	10	0.66	99.94	0.06	21.2
E	3518	3518	0	3518	0	0.00	100.00	0.00	30.4
F	719	597	10	587	132	1.39	81.64	18.36	26.4
G	3546	2237	1	2236	1310	0.03	63.06	36.94	17.4
H	3521	3216	5	3211	310	0.14	91.20	8.80	13.4
I	3518	3442	2	3440	78	0.06	97.78	2.221	0.8
J	3524	3426	0	3426	98	0.00	97.22	2.78	36.0
K	3576	54	1	53	3523	0.03	1.48	98.52	41.0
L	3563	1323	0	1323	2240	0.00	37.13	62.87	41.2
M	3523	3515	1	3514	9	0.03	99.74	0.26	26.4
N	3522	3519	0	3519	3	0.00	99.91	0.09	18.4
O	3527	3525	0	3525	2	0.00	99.94	0.06	12.2

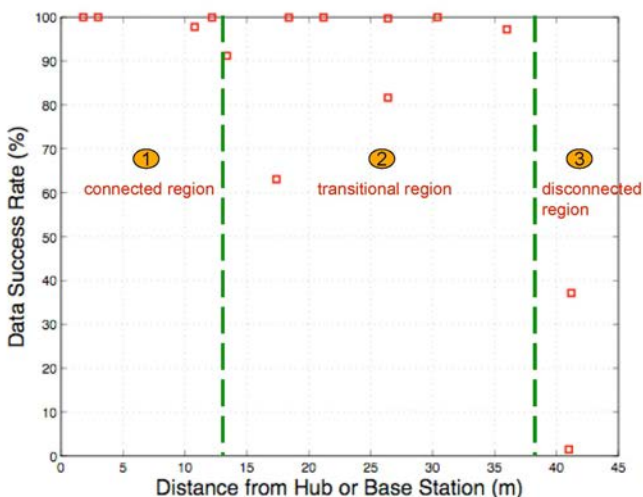

Figure 7. Data success rate for the indoor sensor network.

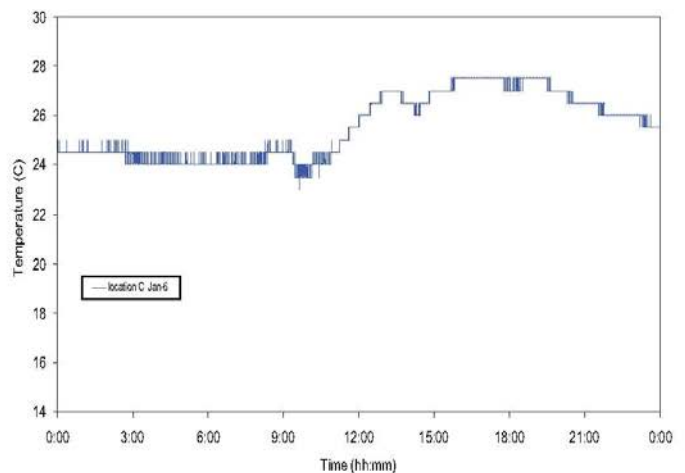

Figure 8. Temperature measurement at location C.

4.2 Data transmission

Tables 1 and 2 indicate the reliability of the data transmission by tabulating the expected number of readings from the nodes against the actual data packets received and were post-processed to determine the number of repeated packets. The data indicates that nodes located within 15m of the hub all exhibited excellent data transmission rates exceeding 90%. Nodes located between 15 to 30m were generally effective with data transmission rates exceeding 60%. Nodes located at distances beyond 40m were not able to provide any reliable data communications.

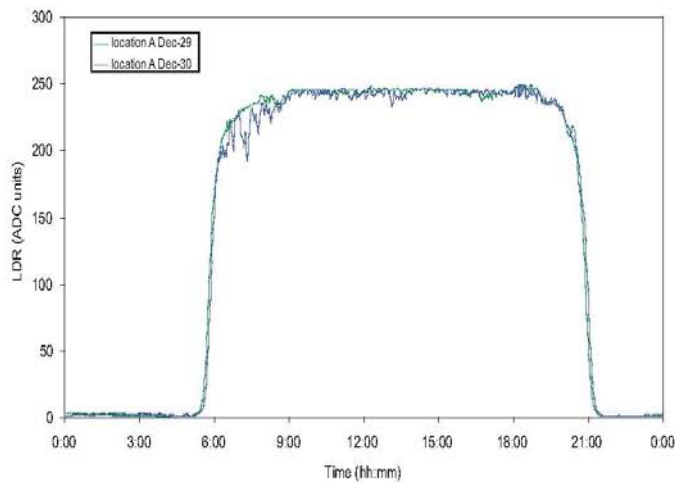

Figure 9. Natural light measurement at location A.

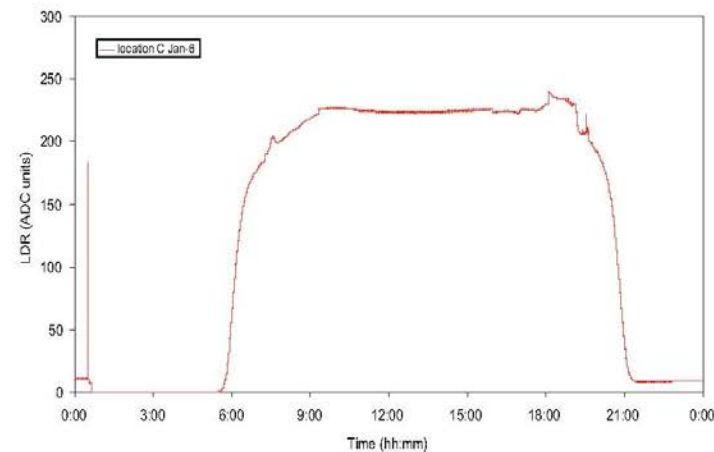

Figure 10. Artificial light measurement at location C.

A plot of the data communication efficiency against distance in Figure 7 shows that the data rate drops significantly beyond a distance of 40m within the building. The results are clearly confirmed the three regions described by Krishnamachari (2005). The transitional region (nodes located between 15 to 30m) is of particular concern in wireless sensor network since it accommodates high variance unreliable links.

The hub coverage area is affected by the type of building material, their thicknesses and to number of other obstacles in the radio pathway. Moreover,

radio waves tend to be reflected or diffracted by conductive objects and rarely penetrate them. The large transitional region in indoor environments could be attributed to the large number of obstacles and reflective surfaces including walls, partitions, office furniture and other items affect as additional absorption term to the path loss.

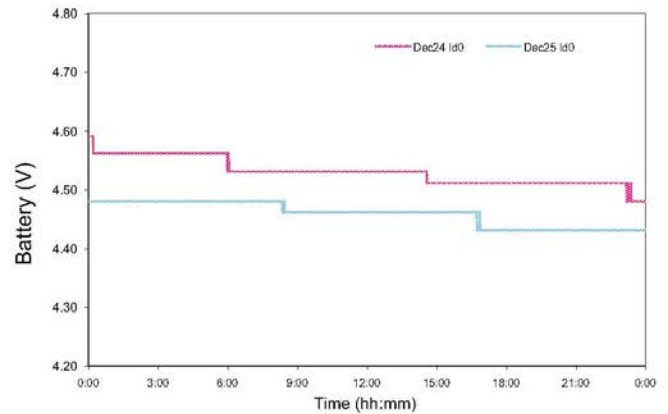

Figure 11. Battery power consumption for Dec. 26 and 27.

5 CONCLUSION

The link quality distribution of a simple wireless sensor network deployed into a single floor of an office building has been investigated. The signal strength has been mapped onto the floor plan and the results confirmed that a large transitional region exists. The transitional region is of particular concern in the deployment of an indoor wireless sensor network since these high variance unreliable links can severely constraint the performance of the network and leads to unduly high power consumption for repeated radio communication attempts. The enlarged transitional region in an indoor office environment could be due to the many obstacles including concrete elements, brick walls, plaster-board partitions, office furniture and other items affect leading to either additional absorption or increase reflectance of the radio waves. Further research is planned to characterise the performance of wireless networks in indoor environments.

REFERENCES

- [1] Amirtharajah, R., Collier, J., Siebert, J., Zhou, B., and Chandrakasan, A., "DSPs for energy harvesting sensors: Applications and architectures", *IEEE Pervasive Computing*, Vol.4, No.3, Sep.2005, pp.72-79.
- [2] Balakrishnan, H., Baliga, R., Curtis, D., Goraczko, M., Miu, A., Priyantha, B., Smith, A., Steele, K., Teller, S. and Wang, K., "Lessons from developing and devolping the cricket indoor location system", MIT, USA, Tech. Rep., Nov. 2003.
- [3] Bluetooth, [online] <http://www.bluetooth.com>.

- [4] Boulis, A., Ganeriwal, S., and Srivastava, M.B., "Aggregation in sensor networks: an energy-accuracy trade-off", in Proc. Int. Sensor Network Protocols and Applications, 2003, pp.128-138.
- [5] Cayirci, E., "Data aggregation and dilution by modulus addressing in wireless sensor networks", IEEE Commun. Lett., Vol.7, No.8, Aug.2003, pp.355-357.
- [6] Halgamuge, M.N., Guru, S.M., and Jennings, A., "Energy efficient cluster formation in wireless sensor networks", in Proc. IEEE Int. Telecommunications Conf. ICT'03., Vol.2, Tahiti, French Polynesia, Feb.-Mar.2003, pp.1571-1576.
- [7] Halgamuge, M.N., Guru, S.M., and Jennings, A., "Centralised strategies for cluster formation in sensor networks", ser. Classification and Clustering for Knowledge Discovery, Springer-Verlag, Aug.2005, ISBN: 3-540-26073-0, pp.315-334.
- [8] Halgamuge, M.N., "Efficient battery management for sensor lifetime", in Proc. IEEE AINA Conf., Vol.1, Niagara Falls, Canada, May 2007, pp.56-61.
- [9] Halgamuge, M.N., Zukerman, M., Ramamohanarao, K., and Vu, H.L., "An estimation of sensor energy consumption", Progress In Electromagnetics Research B, Vol.12, 2009, pp.259-295.
- [10] Heinzelman, W.R., Chandrakasan, A., and Balakrishnan, H., "An application-specific protocol architecture for wireless microsensor networks", IEEE Tran. on Wireless Comm., Vol.1, No.4, Oct.2002, pp.660-670.
- [11] Intanagonwiwat, C., Govindan, R., and Estrin, D., "Directed diffusion: A scalable and robust communication paradigm for sensor networks", University of Southern California, Los Angeles, Tech. Rep.00-732, 2000.
- [12] Jiang, X., Polastre, J., and Culler, D., "Perpetual environmentally powered sensor networks", in Proc. Int. Symp. Information Processing in Sensor Networks, Apr.2005, pp.463-468.
- [13] Kansal, A., and Srivastava, M.B., "An environmental energy harvesting framework for sensor networks", in Proc. Int. Symp. Low Power Electronics and Design Conf., ACM Press, 2003, pp.481-486.
- [14] Kansal, A., Potter, D., and Srivastava, M.B., "Performance aware tasking for environmentally powered sensor networks", in Proc. int. Measurement and modeling of computer systems Conf., New York, USA: ACM Press, 2004, pp.223-234.
- [15] Krishnamachari, B., "Networking Wireless Sensors", Cambridge University Press, 2005.
- [16] Lee, J.J., Krishnamachari, B., and Kuo, C.C.J., "Impact of heterogeneous deployment on lifetime sensing coverage in sensor networks", in Proc. IEEE SECON Conf., Oct.2004, pp.367-376.
- [17] Mainwaring, A., Polastre, J., Szewczyk, R., Culler, D., and Anderson, J., "Wireless sensor networks for habitat monitoring", in Proc. ACM Int. Wireless Sensor Networks and Applications Conf., USA, Sep.2002.
- [18] Mille M.J., and Vaidya, N.H., "A MAC protocol to reduce sensor network energy consumption using a wakeup radio", IEEE Trans. Mobile Computing, Vol.4, No.3, May 2005, pp.228-242.
- [19] Paradiso J.A., and Starner, T., "Energy scavenging for mobile and wireless electronics", IEEE Pervasive Computing, Vol.4, No.1, Jan. 2005, pp.18-27.
- [20] Rahimi, M., Shah, H., Sukhatme, G.S., Heideman, J., and Estrin, D., "Studying the feasibility of energy harvesting in a mobile sensor network", in Proc. IEEE int. Robotics and Automation Conf. ICRA '04, Vol.1, Sep.2003, pp.19-24.
- [21] Roundy, S., Otis, B.P., Chee, Y., Rabaey, J.M., and Wright, P., "A 1.9 GHz RF transmit beacon using environmentally scavenged energy", in Proc. IEEE int. Symp. Low Power Elec. and Devices, Feb.2003.
- [22] Roundy, S.J., "Energy scavenging for wireless sensor nodes with a focus on vibration to electricity conversion", PhD Thesis, The University Of California, Berkeley, 2003.
- [23] Sankarasubramaniam, Y., Akyildiz, I.F., and McLaughlin, S.W., "Energy efficiency based packet size optimization in wireless sensor networks", in Proc. IEEE Int. Sensor Network Protocols and Applications Conf., 2003, pp.1-8.
- [24] Schmid, T., Ferriere, H.D., Vetterli, M., "Sensorscope: Experiences with a wireless building monitoring sensor network", 2006.
- [25] Szewczyk, R., Mainwaring, A., Polastre, J., Anderson, J., and Culler, D., "An analysis of a large scale habitat monitoring application", in Proc. int. Embedded networked sensor systems Conf. SenSys '04, Baltimore, MD, USA: ACM Press, 2004, pp.214-226.
- [26] Szewczyk, R., Osterweil, E., Polastre, J., Hamilton, M., Mainwaring, A., and Estrin, D., "Habitat monitoring with sensor networks, Sensors, Vol.47, No.4, June 2004, pp.34-40.
- [27] www.chip45.com, "iDwaRF product datasheet", 2009.
- [28] Ye, W., Heidemann, J., and Estrin, D., "An energy-efficient MAC protocol for wireless sensor networks", in Proc. IEEE INFOCOM Conf., Vol.3, June 2002, pp.1567-1576.
- [29] Zhang, P., Sadler, C.M., Lyon, S.A., and Martonosi, M., "Hardware design experiences in zebranet", in Proc. SenSys, Feb. 2003.
- [30] Zhao J., and Govindan, R., "Understanding packet delivery performance in dense wireless sensor networks", in Proc. 2nd int. Embedded networked sensor systems Conf. SenSys '03, New York, USA: ACM Press, 2003, pp.1-13.
- [31] Zou, Y., and Chakrabarty, K., "Target localization based on energy considerations in distributed sensor networks", in Proc. IEEE Int. Sensor Network Protocols and Applications Conf., May 2003, pp.51-58.